

FORE! Ketel One Golf Ball Promotion Uses Custom Do-It Bottle Neck Hang Tab



It's a great time of the year. The sun is shining. Birdies are chirping. And Ketel One is using golf balls to promote its Ketel One Vodka.

Do-It Corporation's 2-DET Bottle Neck Hang Tab

Hangs a Ketel One logo imprinted Callaway golf ball around the neck of the 750 ml bottle. Do-It

Corporation's 2-DET Bottle Neck Hang Tab securely displays the golf ball in the clear box as it fits snugly around the neck of the bottle.

Ketel One's logo is digitally printed on one panel of the clear box — complementing the logo printing on the golf ball.

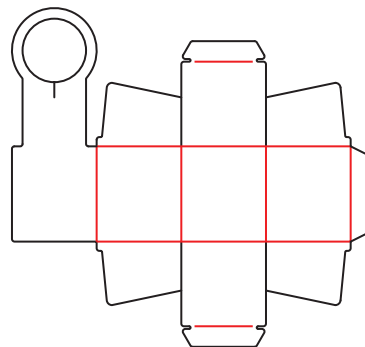

2-DET



In addition to making Ketel One drinking golfers happy, the unique on-product promotion is easily noticed in the store and helps to distinguish Ketel One from other products in any busy liquor aisle.